



FIRE RANGER RESPONSE UNIT



- 300 gal. poly water tank with 10 gal. foam cell
- Hale-Honda 20 HP pump
- Hale 2.1A FoamLogix™ foam system
- Stainless steel piping and valves
- Rugged all welded extruded aluminum body

FIRE
Classic

P. O. Box 4529 • Ocala, FL, USA 34478
PH: 352.351.1347 • FAX: 352.351.1682
www.classicfirellc.com

FEATURES AND SPECIFICATIONS

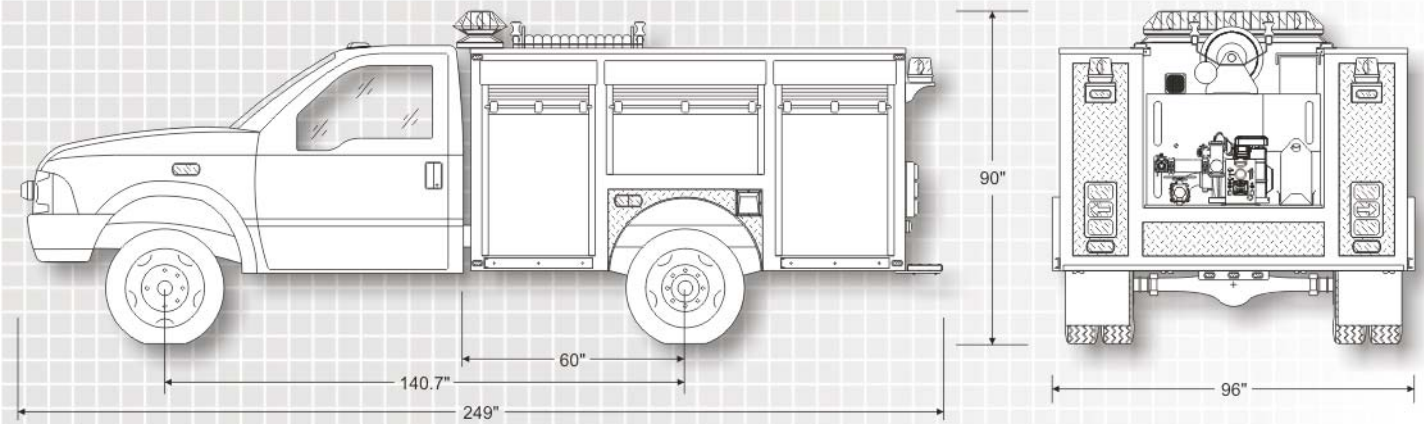

FIRE RANGER RESPONSE UNIT

Chassis:

- Ford F550 2-door
- 17,500 lb. GVWR
- 4x4 all wheel drive
- 6.0 L diesel engine
- 5-speed automatic transmission

Body:

- Rugged all welded extruded aluminum body
- 60" C/A
- Compartments located (4) vertical & (2) over the wheel wells with roller shutter doors

Tank:

- 300 gal. polypropylene water tank with lifetime warranty
- 10 gal. polypropylene integral foam cell with lifetime warranty

Pump & Plumbing:

- Hale HPX 200-H2O Maxstream gasoline pump with 20 hp Honda 4-cycle gasoline engine
- Stainless steel piping
- Hale stainless steel Torrent valves
- 2.5" suction
- 3" tank to pump
- 1.5" rear hoselay discharge
- 1.5" rear discharge
- 1.0" hose reel discharge
- 1.0" tank fill

Foam System:

- Hale 2.1A FoamLogix™ foam system for Class A foam

Hose Reel:

- Hannay 12V electric rewind steel hose reel
- 100' red 1" 800 PSI test booster hose
- 1" POK pistol grip nozzle

Control/Instrument Panel:

Advanced ergonomic control/instrument panel includes electric pump start, pump throttle, digital foam control, discharge gauge, hose reel rewind switch, and instrument light

Warning & Lighting:

- Whelen Centurion Halogen lightbar
- Whelen Halogen warning lights
- Whelen electronic siren with 100 watt speaker
- Work light

Paint:

- DuPont Imron™ Polyurethane Enamel

FIRE
Classic

P. O. Box 4529 • Ocala, FL, USA 34478
PH: 352.351.1347 • FAX: 352.351.1682
www.classicfirellc.com